

RX-4MHCS

433.92 MHz OOK (AM) Receiver - 4 output channels

Description

The mono-stable and bi-stable mode and the open collector outputs make it ideal for telecontrol of appliances like gate door openers, burglar alarm systems and wherever it's requested encoding of radio link. Furthermore it's able to learn the code of HCS transmitters.

Compatible with AUREL keyfobs: HCS-TX-1/2/3 (OVO), TX1/2/3-HCS-433 (HCS), TX-2/4/6 M-HCS, TX-12 CH.

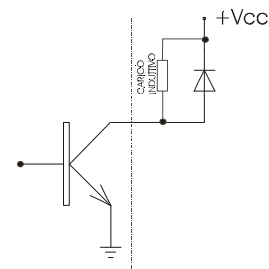
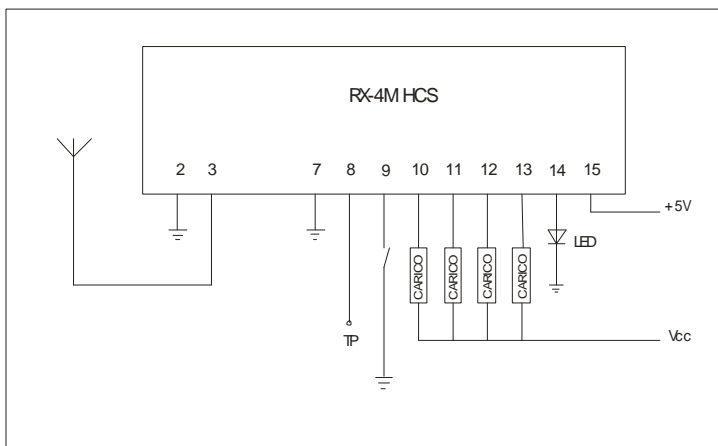
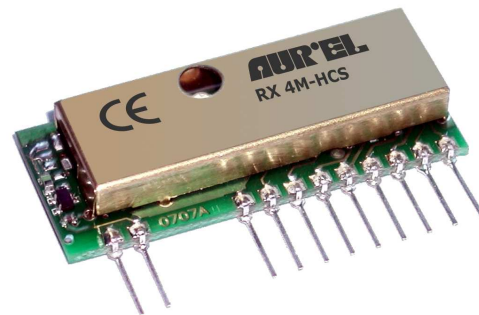

Connection Pin-Out:

- 2) GND
- 3) Antenna
- 7) GND
- 8) Test Point – RX analog output
- 9) Programming push button
- 10) Ch1 output - Open collector (Triggered by pushing button 1 in the keyfob)
- 11) Ch2 output- Open collector (Triggered by pushing button 2 in the keyfob)
- 12) Ch3 output- Open collector (Triggered by pushing button 3 in the keyfob)
- 13) Ch4 output- Open collector (Triggered by pushing button 4 in the keyfob)
- 14) LED output – Connected to anode of LED
- 15) Vcc (+5Volt)

Technical features are subject to change without notice. AUREL S.p.A. does not assume responsibilities for any damages caused by the device's misuse.

How to get started

The voltage supply to the module (pin 15) shall be 5Vdc. Pin 9 shall be connected to the push button for programming the receiver, pin 14 shall be connected to the anode of LED to control that programming has been carried out (output current is internally limited to around 20 mA by a 180 ohm resistor). External antenna shall be connected, by utilizing for example a piece of wire 17 cm long and a surrounding widespread ground plane.

Every output of RX-4MHCS is driven by a transistor in open collector configuration, able to bear max current of 100 mA. In stand-by mode transistor is cut off while when triggered is in saturation region. Output can be programmed to work in mono-stable or bi-stable mode, every one independent from the others.

In mono-stable mode output is active for all the time the corresponding push button is pressed in the keyfob, releasing the button output switches off.

In bi-stable mode output switches its state every time the corresponding push button is pressed in the keyfob (from active to inactive and vice versa). The two operative modes are independent each other, that means it's possible to program some outputs as mono-stable and some others as bi-stable.

If an inductive load is connected to the output (i.e. a relay) it's necessary to prevent voltage transients by putting a diode in parallel to the inductive load. LED anode shall be connected towards the output of the module.

In order to enable the receiver to activate its outputs it's necessary to store in the RX-4MHCS the keyfobs codes. To carry out this operation it's necessary to approach the keyfob to the receiver. By pressing a push button (it doesn't matter which one) of the keyfob during the auto-learning phase, the receiver RX-4MHCS recognises the button pressed and all other channels automatically.

Only the keyfobs with HCS encoder shall be recognised by the receiver RX-4MHCS. Keyfobs not programmed or programmed with manufacturer code different from the one used by AUREL would not be recognised.

Based on reasonable demand, Aurel is willing to program the receiver RX-4MHCS with specific manufacturer code indicated by the customer.

Ground plane

The circuit must be double layer. Ground plane must surround at the best the welding area of the receiver. For further info please refer to the user manuals of AUREL's receivers.

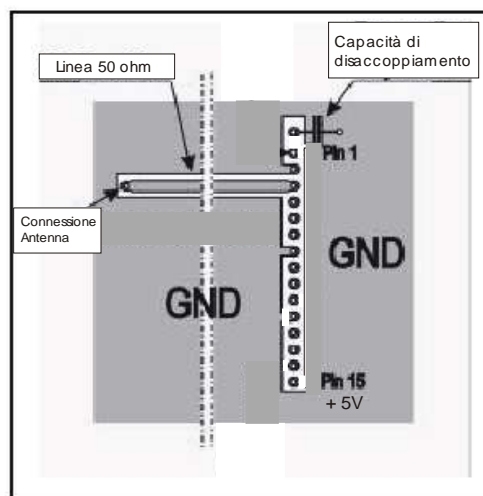

Technical features are subject to change without notice. AUREL S.p.A. does not assume responsibilities for any damages caused by the device's misuse.

Programming

How to erase the memory

In order to reset the RX-4MHCS, press the push button connected to pin 9 and release it when LED starts blinking. Now press again the push button and hold it pressed for around 5 seconds until it switches off again. As you release the push button the LED blinks 5 times indicating that memory has been erased. After carrying out the reset, no HCS encoded keyfob shall be recognised and all outputs shall be set up in mono-stable mode.

Auto-learning procedure

By pressing and soon releasing the programming push button the auto-learning procedure is initiated. LED blinks quickly for 10 seconds: for this time long, every time a push button of a keyfob, located near the RX-4MHCS, is pressed, such keyfob would be learnt. Programming of RX-4MHCS is confirmed by LED with steady red light, afterwards it switches off.

When programmed all push buttons of the keyfob are learnt and each of them activate the corresponding output. Outputs will be mono-stable.

It's possible to repeat this procedure to allow the receiver RX-4MHCS to learn up to 10 keyfobs.

Bi-stable mode programming

To get the bistable output, press and release the programming button, connected to the pin 9.

The LED starts blinking quickly for 10 seconds. Press the programming button again during this time. The LED changes from blinking to steady light. In the next 10 seconds, when the reference LED is steady, it is possible to press the button related to the channel you want to change in bistable mode. The receiver indicates the correct programming of the bistable mode with three LED flashes.

To return the monostable operating mode, repeat the above procedure; in this case, correct programming is indicated by two LED flashes.

Switching the output mode from bistable to monostable can only be done after the receiver has learnt the transmitter.